

MIDIVERTER

μ P Controlled MIDI to CV/Gate/Sequencer Control Module

BLACET RESEARCH MODEL MIDI2910

User & Assembly Manual

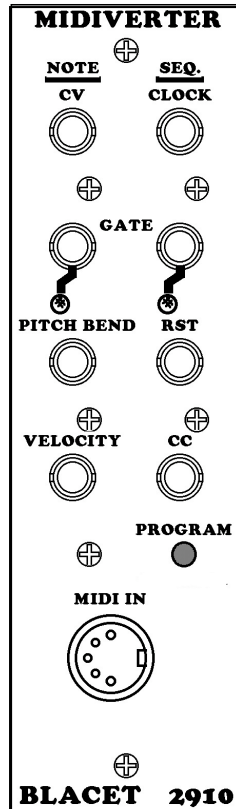

Blacet Research 94502 Stock Drive Lane, Lakeview, OR 97630

blacet@blacet.com <http://www.blacet.com> 541-947-5330

Contents Copyright.

Reproduction by any means including the Internet prohibited without permission.

This document contains proprietary and trade secret information of Blacet Research and is provided as a service to the module owner. Any unauthorized duplication or transferral may violate trade secret laws.

Rev 8-2010

Contents subject to change without notice.

Introduction

The Blacet MIDI2910 MIDiverter is a microprocessor controlled MIDI to note CV, gate and sequencer control converter for use with analog modular systems. The sequencer control functions are designed to interface with our sequential modules such as the Binary Zone and Hex Zone.

The Note output is 5V 12 bit converted single channel 1V/Octave standard for controlling analog modules such as a VCO, Filter, etc. The Note Gate output is designed to control an EG, ADSR, etc.

The Pitch Bend output is +/-5V 12 bit with center zero, with 7 ranges selectable via a CC channel 119 message.

The Velocity output is a 5V 12 bit variable output derived from keyboard velocity.

The CC output can be programmed to follow any MIDI CC message, such as the modulation wheel (CC 1), for example. It is programmed by pushing the Program button and activating the desired controller.

The Sequencer Clock output divides down the MIDI clock to interface with modules such as the Binary Zone and Hex Zone.

The Sequencer Gate output follows the MIDI start/stop and the Sequencer Reset output generates a reset signal from the MIDI input.

The Program Button allows setting the MIDI input channel (1-16), the CC output, the low "C" note, and serves as a Panic (all notes off) button.

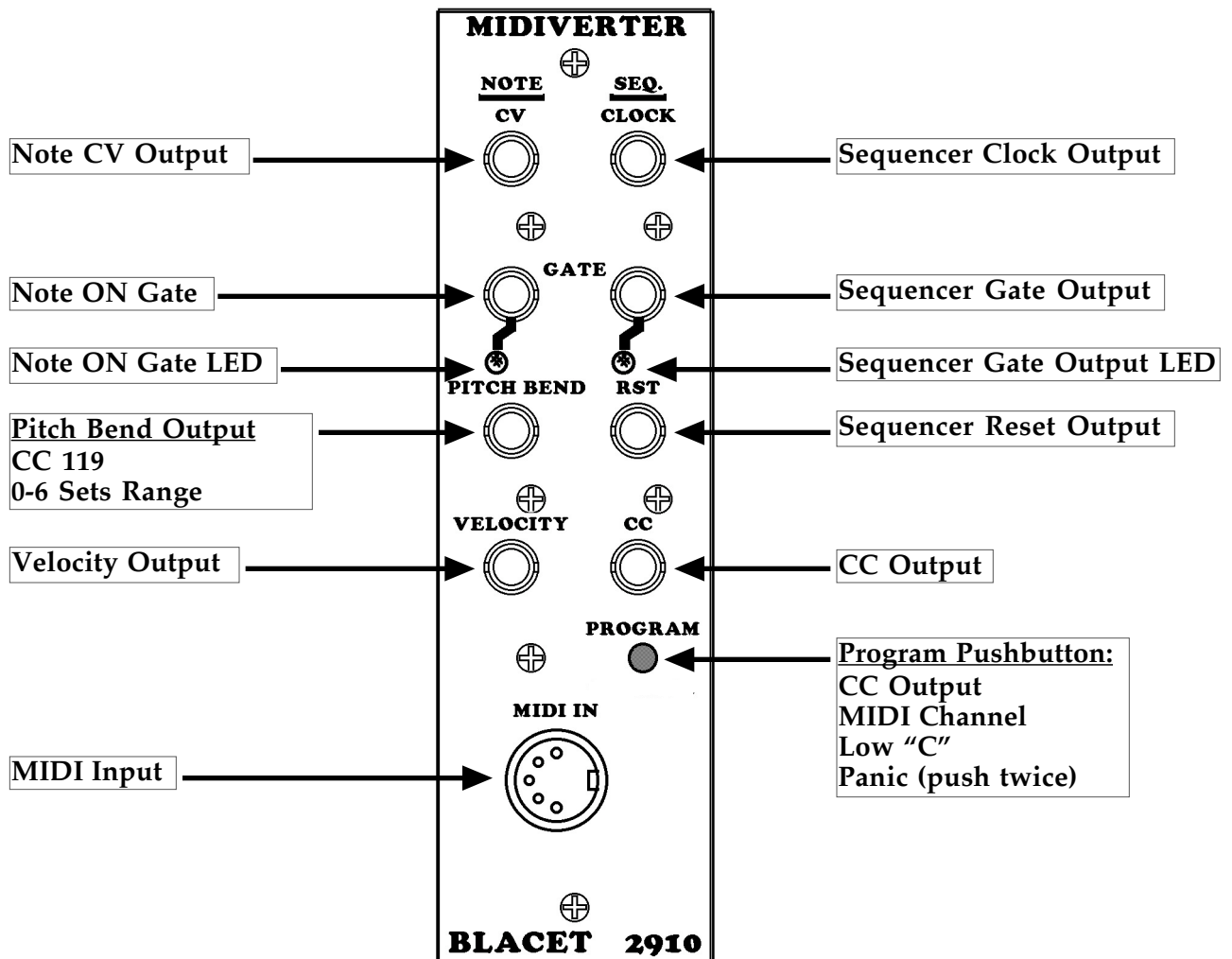

Controls and Operation

Operation of the MIDIVERTER is fairly straight forward. You can use any source of MIDI such as a keyboard, computer program with MIDI output, etc. One very useful source is a MIDI Controller type keyboard. These typically have no built in sounds but have a large number of knobs, buttons, sliders which can be programmed to output any MIDI message. For example, we used the Edirol PCR-300 during development.

A standard patch using the module would connect the Note Out to a VCO, the Pitch Bend to the VCO, the Gate to an ADSR such as the EG1 and the Velocity to a filter such as the Filthy Filtre. The waveform from the VCO would pass through the Filter and be connected to a VCA, such as the Dual Linear VCA. The VCA would be controlled via the EG1 output.

Also, by using a Mixer and/or Splitter, many control options can be derived from the MIDIVERTER outputs for a wide variety of sounds.

The **Pitch Bend** output can be programmed in six ranges by sending a CC 119 message from a rotary knob on your controller. The following ranges are equally spaced on the controller rotation.

- 0 = +/- 1 Note
- 1 = +/- 2 Notes
- 2 = +/- 4 Notes
- 3 = +/- 8 Notes
- 4 = +/- 1 Octave
- 5 = +/- 2 Octaves
- 6 = +/- 5.20 Volts

Although the resolution of this output is 12 bit, many keyboards only output 8 bit. At higher ranges, you will hear "stepping" if this is the case with your controller.

The **Program** button has multiple functions:

- Sets the low "C" note: Push the button and play the lowest "C" on your keyboard that you want the MV to respond to.
- Sets the MIDI receive channel: Press the button and send any message containing channel info. (Play a note on the keyboard other than "C".)
- Sets the CC for the CC output: Press the button and send any CC message from your controller. (Move the Mod Wheel, for example.)
- Turns all notes off (MIDI Panic). Press twice.

The Program button should not be pressed while normally playing the keyboard.

Other features may be programmed by setting up your controller to send various CC messages. (U5 REV 2.09 and above). Consult your controller manual for more specific information.

- **Sustain** off/on (CC 64) (Gate Out is held high.)
- **Legato** off/on (CC 68) (New note gate only when previous keys are released.)
- **LFO Depth** (CC 77) (software LFO added to Note CV)
- **LFO Rate** (CC 76)
- **LFO Type** (CC 85) (Saw, Square, Triangle, Tooth)
- **Arpeggiator** off/on (CC 86) (10 note capacity)
- **Arpeggiator Latch** off/on (CC 89)
- **Arpeggiator Clock Source** LFO/MIDI (CC 87)
- **Arpeggiator MIDI clocks** per step (CC 88). 1, 2, 4, 8, 16, 32
- **Sequence Start** (FA) (System Exclusive Message)
- **Sequence Stop** (FC) (System Exclusive Message)
- **Sequence Continue** (FB) (System Exclusive Message)
- **Sequence Clock Tempo** (TMP) (System Setting)

Power

Power Input Connector PWR: This PCB connector requires a source of regulated +15Vdc and -15Vdc power to run the module. Use a Blacet PS500 supply or the equivalent.

Connections to this connector should be made only when the power supply is OFF and the connector must be positioned correctly on the pins. As using the wrong supply can cause damage to the unit, please contact us if you have any questions! Do not attempt to use "wall warts" to power the module

Specifications

Front Panel Size: 5.25" H x 1.5" W

Module Depth: 3.8"

Input/Output Jacks: 3.5 mm (1/8"), MIDI Jack

Power: +15 Vdc @ 42mA, -15 Vdc @ 10mA