

Introduction

The IO2225 is a versatile input signal processor module designed to amplify signals from a wide variety of sources to standard modular levels of 10V p-p. In addition, a 5V power source is included on the 1/4" Input jack to allow the easy integration of foot pedals, pressure sensors, etc.

The X10 range of the amplifier is DC coupled, allowing for the processing of control voltages.

The envelope of the input signal is available at two outputs with attenuators; with a lag control for the second output.

A comparator with a level control monitors the envelope and extracts Gate and Trigger information to initiate events on other modules.

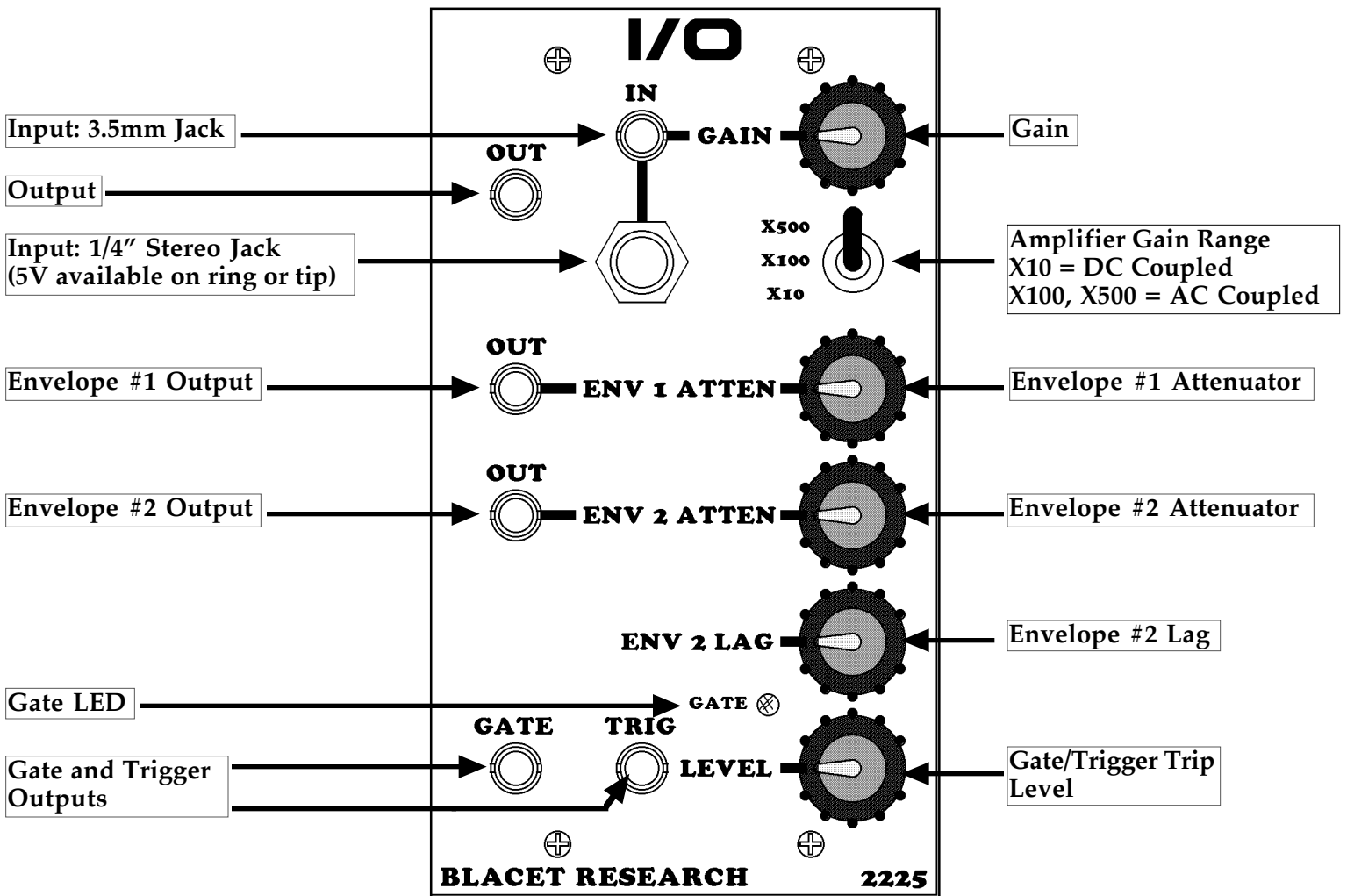

Controls and Operation

Input Jacks, Output Jack, Gain Pot, Range Switch (X10, X100, X500): Before plugging in an external signal, turn the Gain control down and set the Range switch to the minimum required. For example, a line level signal from a keyboard or consumer audio product would need the X10 setting. A non preamped guitar or microphone might require the X100 or X500 setting. Note that the X10 position is DC coupled with low offset voltages, so control voltages can be easily processed.

For the X100/X500 setting, avoid turning the Range pot full CW *without a signal input* as oscillation may occur.

Connect the Out jack to any other module as required; for example the Final Filtre.

The 1/4" input is a stereo jack, allowing for an internal +5V power supply to be connected to external devices. In the standard factory configuration, the +5V is placed on the ring of a stereo input plug, although DIP switches (S2) on the IO PCB allow the user to assign the signal and power functions to either the tip or ring of the stereo plug.

In general, we would advise using the factory settings for S2 as this allows most inputs without having to change the switch settings. For example, using a mono plug for the input, the +5V out sees common and is shut off by internal sensing circuitry. Using a stereo plug places the +5V on the ring of the plug for use with a pedal, etc. Some pedals switch the tip and ring so the option is there on the DIP switch. It may be more convenient, however, to rewire the plug of the pedal if you intend to use it only for the module.

The standard input impedance of the module is 100K, although this can be changed via IO PCB DIP switch S3 to 470K for use with weak signals such as those from a guitar or mike. This may improve high frequency response.

The second section of S3 allows for the disabling of the automatic switching to AC coupling for the X100/X500 ranges. This should be left in the "AC" position unless you are attempting to amplify very small DC signals.

As mentioned above, S2 allows for the configuration of the 1/4" Input jack. (As the two input jacks share a common input to the amplifier section, note that these settings may also effect the 3.5mm Input jack).

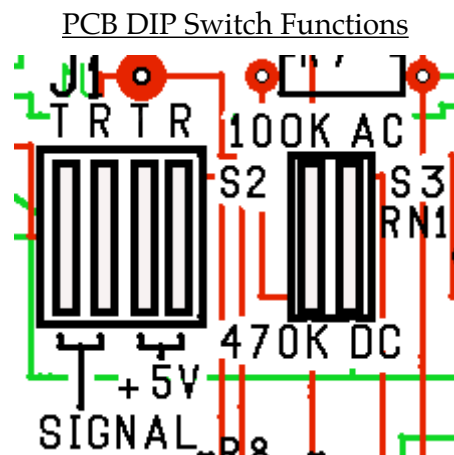

Env 1 Atten Pot, Env 2 Atten Pot, Env 2 Lag Pot, Output jacks: An envelope follower converts the amplified signal to DC and applies low pass filtering to derive a DC voltage proportional to audio level (envelope). This is useful for controlling other modules. Each of the two outputs can be attenuated. The Env 2 output has additional low pass filtering or lag to delay the response of the voltage in relationship to the Env 1 output. These delays are in the 0 to 2 second range.

Gate, LED, Trig Outputs, Level Pot: By comparing the level of the envelope with a setpoint determined by the Level pot, a Gate signal is generated. A trigger pulse is also derived from the leading edge of the gate signal.

Power Input Jack J8: A source of regulated +/-15Vdc power must be supplied to this PCB jack to run the module. Note the current requirements in the "Specifications" section.

Connections to this jack should be made only when the power supply is OFF and the connector must be positioned correctly on the pins. As using the wrong supply can cause damage to the unit, please contact us if you have any questions! Do not attempt to use "wall warts" to power the module.